



**FALCON RS500 REMOTE ENGINE STARTER**  
**Owner's & Installer's Manual**

070724

**00. SYSTEM FEATURES**

01. Tach or Tachless Start (Alternator)
02. Smart RPM Learning Adjuster
03. Optional +/- Glow Plug Input
04. Turbo Timer
05. Timer Start
06. Programmable Engine Running Time
07. Programmable Cranking Time
08. Bypass Output
09. Safety Wire
10. Compatible with Auto or Manual Transmission
11. Anti-grind

**11. SYSTEM OPERATION**

**01. Start & Stop the Engine (input W3-4)**

- a. Feeding W3-4 with a negative pulse will start or stop the engine running alternately.
- b. During the turbo timer mode, feeding W3-4 with a negative pulse will stop the turbo timer IMMEDIATELY.
- c. During engine running, feeding W3-4 with a negative pulse will stop the engine running.

\* To drive the car once the engine has been started by the RS500 (or in turbo timer mode):

- Disarm the car alarm.
- Insert the car key into the ignition then switch to On position.
- Step on the footbrake or take the handbrake off then go (depends on the wiring of W2-8).

\* The engine will shut down if the footbrake is tapped or handbrake taken off before switching the ignition on.

**03. Bypass Output (output W3-3)**

This wire is designed for bypassing a factory fitted transponder immobiliser using a separate bypass module or for connection to an alarm systems bypass input.

- a. The RS500 will output a constant negative signal through W3-3 during engine start or turbo timer mode.
- b. The constant negative signal will halt when the engine start or turbo timer mode is stopped.

**04. Glow Plug (wait-to-start input -W3-1 or +W3-2)**

These wires are designed for use with diesel engines. Select W3-1 or +W3-2 depends on the polarity.

- a. For cars equipped with a diesel engine, this wire must be connected to the wait-to-start light in the dashboard.  
 Connect W3-1 to the wait-to-start light if the light is negative trigger or connect W3-2 to the light if positive trigger.
- b. For cars equipped with a petrol engine, connect W3-1 to ground or W3-2 to +12VDC source.

**05. Safety Wire (input W2-7 & W2-8)**

- a. Connect W2-7 to the bonnet pin switch. The switch must provide a ground output when the bonnet is opened.
- b. Connect W2-8 to the handbrake. The handbrake must provide a ground output when the handbrake is pulled up.
- b. The engine will stop running or not be started when W2-7 is fed with ground or W2-8 is fed with positive.

**06. Output to Starter Disable Relay/Anti Grind (W2-5)**

The Anti Grind feature prevents the user attempting to start to the car again by turning the ignition key when the car is already running under remote start. Ensure that the RS500 output to the starter (W1-2) is connected on the starter motor side of the relay cut.

**07. Output to ACC-2 (W2-2) and Output to IGNITION-2 (W2-3)**

Some vehicles have more than one accessory or ignition wire that must be energised in order for the vehicle to run properly or for heating and air conditioning to operate. These outputs are 500mA NEGATIVE so relays must be used when connecting either of these outputs.

**08. Optional Features Table**

No	Features	1 Flash	2 Flash	3 Flash	4 Flash
#1	Engine Sense Mode	Alternator	Tach		
#2	Cranking Time	600ms	800ms	1000ms	
#3	Engine Running Time	10min.	20min.	30min.	
#4	Turbo Timer	Disable	2min.	3min.	
#5	Timer Start	4hour	8hour	12hour	24hour

---

## 09. Program the Optional Features

Follow the steps below to program the optional features:

- a. Turn the ignition on then off with the RS500 deactivated.
  - b. Within 10 sec., press the valet switch three times.
  - c. The hazard lights will be on for 1 sec. to confirm the module is in programming mode.
  - d. Within 10 sec., press the valet switch the same number of times as the option No. you wish to program.
  - e. The hazard lights will flash the same number of times as the item being selected to confirm the selection.
  - g. Then, press and hold the valet switch and the hazard lights will flash 1-4 times as per the optional features.
  - h. Release the valet switch when the hazard lights have flashed the same number of times as the desired feature.
  - i. Press the valet switch 1-5 times to select the next item for programming.
- \* During the programming mode, if the valet switch is not pressed within 10 sec. or the ignition is turned on then the system will leave the programming mode and the hazard lights will flash once to confirm.

## 10. Explanation of the Optional Features

### #1 Engine Sense Mode

Default: Alternator (auto-sense)

When set as: Tach

Connect W2-7 to the ignition coil(-). RPM learning has to be performed as follows before initial operation:

- a. Turn off all the devices such as Stereo, Radio, and air conditioning etc.
  - b. Shift the gear to neutral or parking position (and pull up the handbrake).
  - c. Switch the ignition on, start the engine and release the footbrake until idling.
  - d. Press and hold the valet switch for 2 sec. when the tachometer (rev counter) is about 800rpm and the LED is on.
  - e. Release the valet switch when the hazard lights turn on to confirm the RPM learning is completed.
- \* If the LED is still off when the tachometer is about 800rpm then turn the V.R. until the LED is just on.

### #2 Cranking Time

Default: 600ms

If the engine doesn't start smoothly, then set the crank time longer.

### #3 Engine Running Time

Default: 10 minutes

The engine will run for 10, 20 or 30 minutes as programmed and then shut down automatically.

### #4 Turbo Timer

Default: Disable

The turbo timer will not be activated.

When set as: 2 or 3 minutes

- a. The engine will continue to run for 2 or 3 minutes (depending on setting) after the ignition is turned off.
  - b. The operation is as follows:
    - Keep the engine running.
    - Pull up the handbrake.
    - Turn the ignition key to the off position, the ACC. and ignition circuits will stay on for 2 or 3 minutes as programmed and then shut down automatically.
- \* The turbo timer is functional only when the engine has been running for at least 10 sec.
- c. The turbo timer mode will be interrupted if any of the following occurs:
    - The wire W2-7 shows a ground input.
    - The wire W2-8 shows +12V.
    - The wire W3-4 shows a negative pulse.

### #5 Timer Start

Default: 4 hour

The engine will start automatically every 4 hours.

When set as: 12 or 24 hour

The engine will start automatically every 12 or 24 hours as programmed.

The setting (4, 12 or 24 hours) of timer start has to be turned on as follows before initial operation .

- Switch the ignition on then off
  - Press and hold the valet switch within 10 seconds of switching the ignition off and release after the hazard lights have flashed twice to confirm the timer start feature is turned on. The system starts to count time (4, 12 or 24 as programmed).
- \* Repeat above steps to turn on the timer start feature if the footbrake has been tapped or handbrake has been released with the engine running.

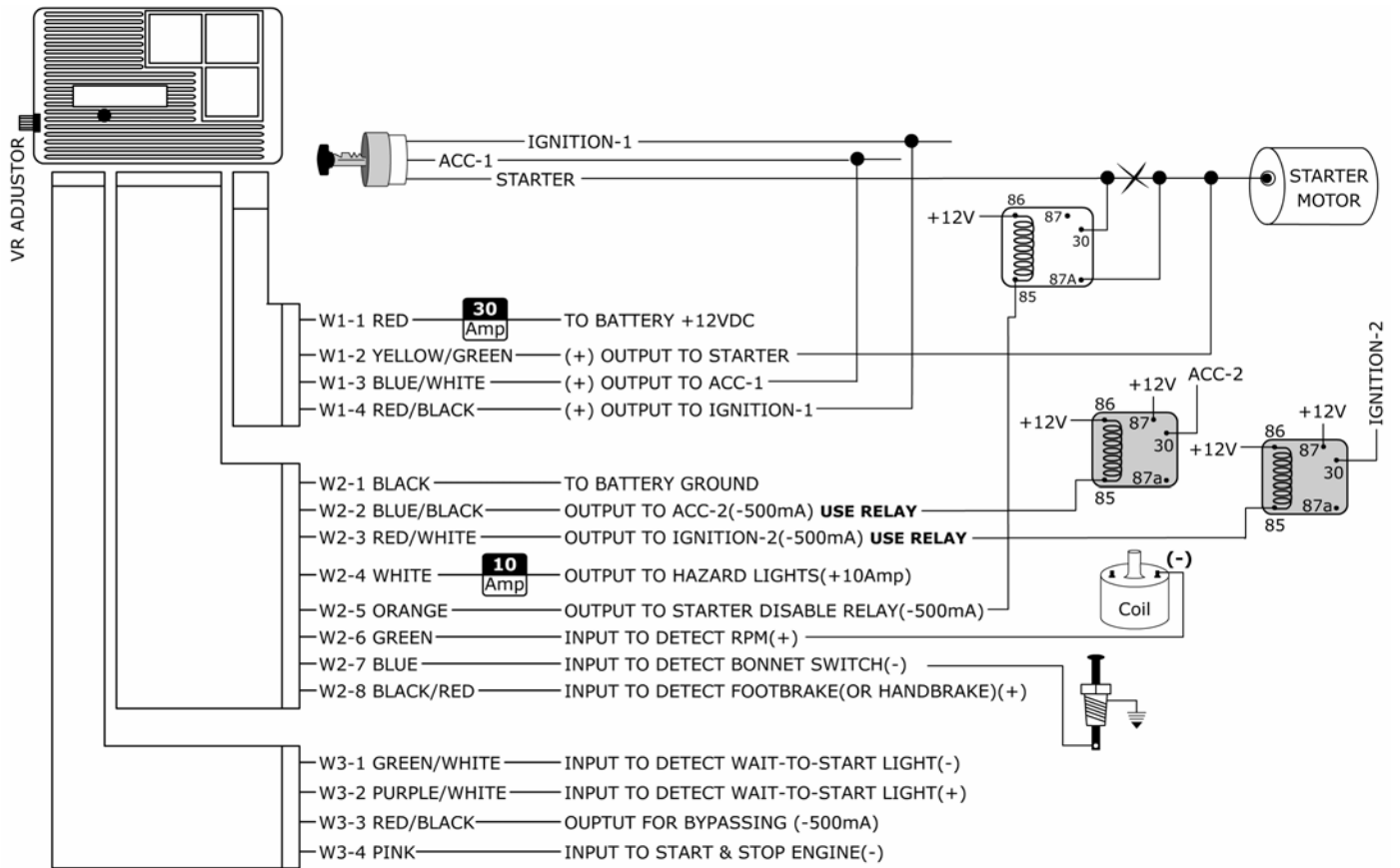

**IMPORTANT NOTE:** W2-2 & W2-3 ARE ONLY REQUIRED FOR CARS WITH ACC-2 OR IGNITION-2, THESE WIRES ARE *NEGATIVE OUTPUTS* THEREFORE A RELAY IS REQUIRED FOR EACH IF THEY ARE USED.